

CONSPEC®

P2259/60

MULTI-CHANNEL GAS CONTROLLER

**OPERATION MANUAL
&
INSTALLATION GUIDE**

6 Guttman Blvd.
Charleroi, PA 15022

VERSION 021005

TABLE OF CONTENTS

I.	Hardware Description	Pages 3-4
II.	Initial Installation	Page 4
III.	Switch Settings	Page 5
IV.	System Start-Up	Page 5
V.	Main Menu	Page 6
VI.	Function Details of Main Menu	Pages 6-17
VII.	System Outputs	Page 17
VIII.	User Outputs	Page 18
IX.	Available Options	Page 18
X.	Remote Switch Calibration	Page 19
XI.	Gas Calibration of Remote Sensors	Page 20
XII.	Manual Gas Calibration	Page 21
XIII.	Appendices	Page 22
XIV.	Wiring Diagrams	Pages 23-30

I. HARDWARE DESCRIPTION

A) P2275 MULTI-FUNCTION PROCESSOR BOARD

The Multi-Function Processor Board is the brain of the system. It is a HD64180 based microcomputer board which includes the following major function blocks: EPROM -Stores the system firmware and default values, RAM-stores the collected data and system operations, EEPROM- stores the programmed configurations and calibration data. Eight (8) channels of 12 bit Analog to Digital conversion.

B) P2301 MULTIPLE SENSOR INTERFACE BOARD

The Multiple Sensor Interface Board is the I/O (Input and Output) Interface between the Multi-Function Processor and the rest of the system. It includes major function blocks: eight (8) Analog input channels to connect to the analog to digital converter, Remote sensor LED drive circuits, one (1) for each Remote sensor. Four (4) Open collector Outputs (Normal, Alarm Level #1, Alarm Level #2, and Sensor Fail) for each Remote sensor. A total of Three (3) Open collector outputs (Strobe, Warning and Alarm) to indicate the system status of all Remote sensors connected to the system. Eight (8) Binary input circuits to monitor the calibration switch operation of the Remote sensors. A connection for the Optional Analog Output Module is available.

C) P2372 GRAPHIC LCD DISPLAY

The Graphic Liquid Crystal Dot Matrix Display (64 x 240 dots) is used to display system or sensor information. The following can be displayed: I) the Main Menu of the System Functions. II) Up to eight (8) windows displaying simultaneously the readings of the Eight (8) Remote sensors and their status. III) Displaying detail reading of a selected sensor. IV) A Bar Graph displaying up to eight (8) sensor readings. V) The configurable parameters of each Remote sensor with help instructions on the screen.

D) P2306 KEYPAD

The Keypad is used for entering data, selecting the system functions and the programming of each Remote sensor. The system uses password protection, entered via the Keypad, to prevent unauthorized access.

E) HISTORICAL TRENDING

The system provides trend graph for the historical data of the selected Remote sensor with selectable interval of 15 minutes, 3,6,9,12,15,18, or 24 hours. This information can be used to analyze the gas readings of the Remote sensor.

F) P2273 REMOTE CELL INTERFACE CARD

The P2273 Remote Cell Interface Card is required to interface each Remote sensor to the P2259/60 Multi-Channel Gas Controller System. Four (4) are supplied with the P2259 Four (4) Channel and Eight (8) are supplied with the P2260 Eight (8) Channel System.

G) DC POWER SUPPLY

When the Multi-Channel Gas Controller System is used as a stand-alone system, a DC Power Supply is supplied with the system to convert the 120 VAC input Voltage to low Voltage DC for use with the system. A 1 Amp fast acting fuse is provided in the hot AC input line (Black line) connection terminal. Optional power supplies are available for use with other input voltages. Consult the factory for further information.

H) P2303 OPTIONAL ANALOG OUTPUT MODULE

Up to two (2) P2303 Analog Output Modules can be installed in the Multi-channel Gas Controller. Each module is capable of providing four (4) Channels of 4 to 20mA output or 0 to 5V output. Each channel can be programmed to represent the gas reading of a Remote sensor connected to the System.

I) OPTIONAL PARALLEL PRINTER or INTERNAL THERMAL PRINTER

An Optional Parallel printer can be connected via the Optional P2342 Parallel Printer Port to provide the user with a hard copy of alarm occurrences, the current system configuration, or the current channel configuration.. An Optional P2370 Internal Thermal Printer capable of printing 20 characters per line can be installed in the controller housing.

J) OPTIONAL RS-232 or RS-485 PORT

For RS-232 or RS-485 communication.

II. INITIAL INSTALLATION OF MULTI-CHANNEL DETECTION SYSTEM

MOUNTING THE CONTROLLER & REMOTE SENSORS

1. Locate a suitable position where the P2259/60 is to be installed. Securely mount the controller with the mounting brackets provided. Make sure you leave enough room to open the front of the cabinet. Locate appropriate positions for the Remote sensors to be located. Securely mount the Remote sensors using industry approved methods and materials taking into account sound mechanical practices. (NOTE: It is the user's responsibility to follow all applicable building codes and electrical codes).
2. Connect the 120V 50-60 Hz AC power to the P2259/60 Multi-Channel Gas Controller System terminal block labeled AC IN. **DO NOT POWER UP YET.** The system is protected by a 1A Fast Acting fuse contained in the terminal block on the AC LIVE (Black Wire) terminal. The AC input is converted into low voltage (24V) DC for use by the system and sensors. The same power supply is used in both the P2259 and P2260. ***Do Not Apply AC Power To The Controller Until You Are Ready To Operate The Controller.*** (Only replace fuse with same rating and type.)
3. Connect the cables from the Remote Sensors according to drawing #10825 for 4-Wire sensors (or drawing #10826 for 5-Wire Sensors) to the terminal block on the card cage inside the controller. ***Pay special attention to drawing # 10826 when connecting to a 5-wire sensor.***

Each Remote sensor is connected to the Remote Cell Interface Card via a 4-wire cable (5-wire cable for Remote Combustible, Hydrogen or Methane sensors). The 4-wire cable consists of two (2) independent circuits, each operating over two (2) wires. The first pair of wires operates as a 4-20 mA current loop that represents the gas concentration. The second pair of wires is used to power and control the LED in the Remote sensor as well as monitor the calibration switch in the Remote sensor. The fifth wire is used as a common in the 5-wires required for certain sensors. Check to make certain that the cable connection between the controller and the Remote sensor is secure. **MOST PROBLEMS ARE CAUSED BY INCORRECT WIRING.**

III. SWITCH SETTINGS

Located on the P2275 Multi-function Processor Board is an 8-position Dip Switch for setting the start-up system configuration. A reset push-button is also available for resetting of the CPU if needed. A power "ON" LED is located on the top of the P2275 Multi-Function Processor Board to indicate when power is being supplied to the board. The switch settings for the 8-position Dip Switch are:

SWITCH 1-ON - System starts up cold. The EEPROM data will not be loaded into the system and system will start up with the default values. The switch **MUST** be set in this position on initial system start-up or whenever cables are changed from the system to the Remote sensors to allow adjustment of the Remote Cell Interface Card for sensor cable length.

SWITCH 1- OFF - System will load all the EEPROM stored data upon start-up or after power interruption. This is the Normal Setting after initial system setup.

SWITCH 2 - ON - System will adopt a 30-second delay time (before sensor readings begin) upon start-up or after power interruption.

SWITCH 2 - OFF - System will adopt a 2-minute delay time (before sensor readings begin) upon a start-up or after power interruption.

ALL OTHER SWITCHES - NOT USED.

IV. SYSTEM START-UP

When the Multi-Channel Gas Controller System is powered up, if Switch 1 of the Dip Switch described above in this manual is in "ON" position, the LCD will show:

CONSPEC CONTROLS - MULTI-GAS SENSOR
VERSION X.XX
COLD START (SW-1 ON) USING DEFAULTS

The screen will remain idle for the delay time selected by Switch 2 of the Dip switch. After the delay time, the LCD will show the MAIN MENU with functions available for selection. The UP and DOWN arrow keys located on the keypad allow scrolling to additional selections. The system will start up using the default values preprogrammed in the firmware.

If Switch 1 of the Dip switch is in the "OFF" position, the LCD will instead show:

<p>CONSPEC CONTROLS-MULTI-GAS SENSOR Version X.XX EEPROM START (SW-1 OFF) VERIFYING EEPROM DATA PASSED</p>
--

After the system loads the data stored in the EEPROM, the system will verify the data's integrity. Then the screen will remain idle for the delay time selected by Switch 2 of the Dip switch. After the delay time, the LCD will show the MAIN MENU with functions available for selection. The

UP/DOWN arrow keys located on the keypad allow scrolling to additional selections. The system will start up using the EEPROM values programmed into the system.

V. MAIN MENU

Once the MAIN MENU is displayed, the following functions are available for selection:

- II VIEW DATA (ALL)
- II DISPLAY SINGLE
- II CONFIGURE INPUTS
- II SAVE TO EEPROM
- II VERIFY EEPROM
- II SET COMM PARAMETERS
- II ALTER PASSWORD
- II CALIBRATE ANALOG OUTPUT
- II ENTER VIEW TIME
- II ENTER USER PLOT DATA
- II PRINTER REQUESTS
- II DISPLAY MEMORY

The LCD will not show all of the above functions on one screen. The operator can use the UP/DOWN arrow keys, located on the keypad, to scroll the screen to display selections not showing. The top line displayed on the screen is always the function to be selected. To select any function from the MAIN MENU, scroll the screen until that function appears at the top of the screen and press "ENTER/YES" key. If the function selected is password protected, you will be prompted to enter the correct password before you can proceed.

VI. FUNCTION DETAILS OF THE MAIN MENU

1. VIEW DATA (ALL)

When this function is selected by pressing the "ENTER/YES" key the LCD will display:

MULTIPLE ANALOG- VALUE DISPLAY

DISPLAY AS BAR GRAPH (Y/N)?_

If the user presses the "ENTER/YES" a Dynamic Bar Graph will show the values of the active channels (in percentage of Full Scale value set for each channel) will be displayed.

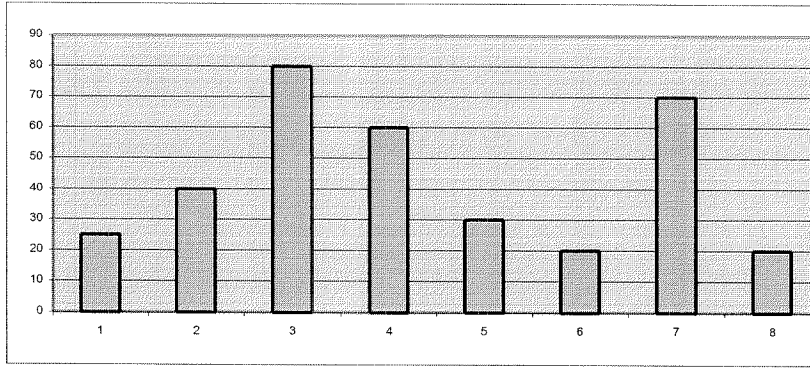

Pressing the “UP” arrow key will zoom the displays Y-Axis. The display can be zoomed to 50%, 20%, or 10% of the Full Scale value. Pressing the “DOWN” arrow key will return to the previous range displayed. To EXIT from the Dynamic Bar Graph display, press the “MENU” key on the keypad.

If the “NO” key is pressed when the LCD prompt is “DISPLAY AS BAR GRAPH (Y/N)?-” the LCD will display the value of the active channels in the following format:

CONSPEC CONTROLS-MULTIGAS SENSOR X.XX			
#1-CH4	#2-CO	#3-SO2	#4-CO
0.15	1.0	0.1	15.0
%	PPM	ZERO	WARNING
#5-O2	#6-CO		
21.0	25.0		
CAL SPAN	ALARM		

This screen will show all of the active window numbers, the type of each Remote sensor connected, the cm-vent reading of each Remote sensor, and the status of each Remote sensor. If a Remote sensor is in the normal condition, then the engineering unit will be display, otherwise the status of the Remote sensor will be shown.

2. **DISPLAY (SINGLE)**

When this function is selected, the system will prompt on the LCD for the current number to be displayed (Channel # 1-8). After pressing the desired Channel number (1 to 8) and then pressing the “ENTER/YES” key to verify your entry, the display will show

SINGLE ANALOG- VALUE DISPLAY
DISPLAY AS TREND GRAPH (Y/N)? _

To display a Trend Graph for the selected channel, press the “ENTER/YES” key. Otherwise, press the “NO” key on the keypad. If the “ENTER/YES” has been pressed, the LCD will prompt you as shown.

SINGLE ANALOG- VALUE DISPLAY
DISPLAY AS TREND GRAPH (Y/N)? _
TIME SCALE 0=15M 1=3M 2=6M 3=9M
4=12M 5=16M 6=18M 7=STILL 8=24H

The user next selects the window size of the trend graph by entering the desired selection number on the keypad and then pressing the "ENTER/YES" key. The system will then display on the LCD, the Historical data of the selected channel for the selected time period in the Trend Graph Format.

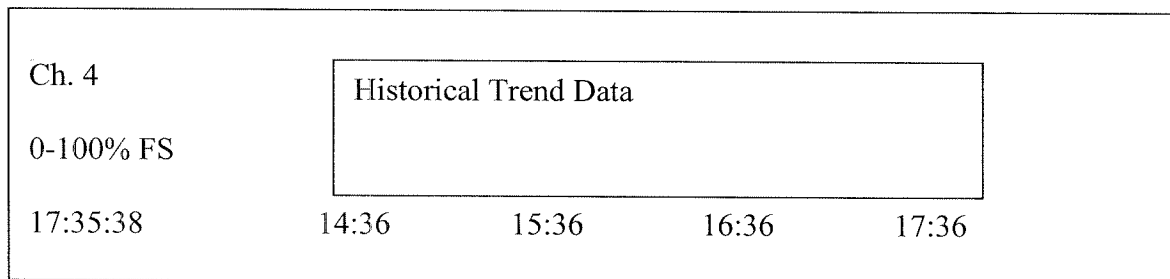

The Trend Graph is a dynamic display unless STILL has been selected as the time period. As new data is collected through the passage of time, the graph will shift from the right to the left and the time scale on the X-axis will change accordingly. The shorter the time period selected for display, the more rapid the movement of time scale of the display. If the "NO" key is pressed when the LCD displays:

SINGLE ANALOG- VALUE DISPLAY
DISPLAY AS TREND GRAPH (Y/N)? _

The LCD will show the values of the selected channel in the following format:

DISPLAY (SINGLE)		
ANALOG INPUT #2		NORMAL
RAW READING (A/D):	412	413
SCALE BINARY:	7	
SCALE ENGINEERING:	1.2PPM	CO
AOUT BINARY (D/A):	0	

This screen indicates the selected channel number, status and value. The RAW READING (A /D): The first column number (which changes rapidly) is the INSTANTANEOUS BINARY READING from the 12-bit A/D converter. The second column number is the AVERAGE READING taken over

the predefined number of samples set in the channel configuration menu. The SCALE BINARY VALUE is the actual binary number that is being sent back to the Central Station on the trunk cable. The SCALE ENGINEERING number is the concentration of the gas detected by the Remote sensor. The AOUT BINARY (D/A) is the binary number that is sent to the Optional Analog output module that converts it to the proportional analog output.

3. CONFIGURE INPUTS

This function is factory preprogrammed but the operator can redefine all of the parameters for the selected channel if needed. This function is required to be programmed when the system is first installed. The user is advised to enter this menu selection and to set the correct values needed for proper system operation. A data sheet is included with the controller that shows the initial system configuration before leaving the factory.

Once this function is selected, the LCD will prompt the operator to enter the current password, if an incorrect password is entered, the system will exit back to the main menu. When the correct password is entered, the LCD will prompt the user for the channel number to configure. (The operator is required to press the “ENTER/YES” key after entering the password and after entering the channel number selection). The password preset at the factory is “1”. (The password is 1234 if the default setting is used instead of the EEPROM setting.)

Once inside the Configure Inputs function, the LCD will display all of the parameters that can be programmed by the operator. Help instructions are available for entering each parameter and appear at the bottom of the screen. The following pages show and describe the parameters that need to be configured for proper system operation.

A. CHANNEL CONFIGURATION

	See Page #
Sensor Type:	10
Unit Used For Display:	10
Input Active (In Scan):	10
Display Window #:	10
Number of Decimals:	10
Low Range Value:	10
High Range Value:	10
Full Range Binary Value:	10
# Readings For Average:	11
User Output Operation:	11
Calibration Enable:	11
Span Gas Value:	11
Zero CAL Time:	12
Span CAL Time:	12
Recovery Time:	12
Alarm Type:	12
Alarm Level #1:	12
Alarm Level #2:	12
Delay To Alarm:	12
Sensor LED Operation:	12
Raw Zero Count:	13
Raw Span Count:	13
AOUT Zero Count:	13
AOUT Span Count:	13
CAL Alarm Level % Change:	13
Analog Output Channel	14
A-Out Cal Operation (0-4)	14
Auto Report on Exceedance:	14

These parameters are displayed on the LCD screen in six (6) pages with the first five (5) pages showing five (5) parameter entries on each, with the remaining parameters on the last page. The operator can use the UP or DOWN arrow keys to advance or scroll to next entry or return to the previous entry for correction (NOTE: The current entry is NOT changed or amended by pressing the UP or DOWN arrow keys).

B. CHANGING PARAMETERS

To enter a new parameter the operator is required to first **ERASE** the current value displayed by pressing the "CLEAR" key (except when a Y/N answer is required). Multiple pressing of the "CLEAR" key may be required to erase long, current entries. Enter the new value by pressing the keys on the keypad then confirm it by pressing the "ENTER/YES" key.

SENSOR TYPE

There are eight (8) nomenclature that can be selected for the Remote sensor, actual name various depends on the firmware version. These names include:

NONE, CO, CH₄, LEL, H₂S, NO₂, HCl, H₂, Cl₂, NH₃, CO₂

UNIT USED FOR DISPLAY

The three types of engineering units available for selection are:

0-NONE 1 -PPM 2- %

INPUT ACTIVE (IN SCAN) Y/N

The operator can choose to activate or deactivate a channel. If a channel is deactivated, its value will not be displayed and no alarm output will be generated.

DISPLAY WINDOW NUMBER

There are eight (8) windows on the LCD that the operator can assign to display the selected channel inside. The windows are numbered one (1) through eight (8). A selection of window number zero (0) results in the selected channel not being displayed on the LCD. Each channel must be assigned to a different window number or window #0. It is recommended that channel #1 be displayed in window #1 and channel #2 in window #2 and so forth. The operator must insure that two or more gas channels are not assigned to the same display window. The windows are numbered as follows:

1	2	3	4
5	6	7	8

NUMBER OF DECIMALS

This entry allows the operator to define the numbering format used by the system, to display the Remote sensor gas concentration on the LCD for that gas channel. The bottom of the screen shows how the gas concentration will be displayed. A sensible numbering format would be more meaningful when displaying gas reading on the LCD.

LOW RANGE VALUE

The operator must provide the low range value, in correct engineering units, for the channel. If a decimal number was chosen above (Number of decimals >0), then a decimal number will need to

be entered. The system will automatically insert the decimal point for you. (E.g., Entering 100 will become 1.00 if 2 is the Number of decimals selected, 10.0 if 1 is the Number of decimals selected). This value is also the Zero scale gas concentration used for calibration.

HIGH RANGE VALUE

This value defines the maximum gas concentration that can be detected by the Remote sensor connected to this channel. The operator must provide the High range value, in correct engineering units, for the channel. If a decimal number was chosen above (Number of decimals >0), then a decimal number will need to be entered. The system will automatically insert the decimal point for you. (E.g., Entering 1000 will become 10.00 if 2 is the Number of decimals selected, 100.0 if 1 is the Number of decimals selected).

FULL SCALE BINARY VALUE

This value defines the number of bits that will be sent back to the Conspec Central Station on a network. This binary number represents the gas concentration on this channel. For 8-bit data communication, 255 should be used for this entry.

NUMBER OF READLNGS FOR AVERAGE

THE P2259/60 MULIT-CHANNEL CONTROLLER system utilizes a microcomputer that operates at a high speed, thus the data from each Remote sensor is collected and stored at a high speed. This provides extremely rapid data collection and hence the value on the LCD (as well as the data being sent back to the Central Station) is rapidly changing. It may not be desirable to view or transmit these rapidly changing bit numbers. This parameter allows the operator to request the system to perform an averaging over a defined number of samples, without affecting the speed of data collection from the sensors, before displaying or transmitting the information. Increasing the number of readings for averaging will minimize the bit changes of the data being displayed on the LCD and the bit changes of the data being sent back to the Central Station.

USER OUTPUT OPERATION

Each gas channel of the system has four (4) unlatched open collector outputs available for user output operations. These outputs can be defined to operate in one of the following ways:

- 0- NONE (No output at all)
- 1 - STATUS of the Remote sensor. The four (4) unlatched outputs represent the four (4) possible status conditions of the Remote sensor attached to the selected Channel. See the Appendix for wiring information.
The status conditions of the attached Remote sensor are:
 - NORMAL
 - ALARM LEVEL #1 (WARN~G)
 - ALARM LEVEL #2 (ALARM)
 - SENSOR FAIL

***NOTE: These outputs will be turned "OFF" during calibration.**

- 2- CALIBRATION STATUS of the Remote sensor. Three (3) of the four (4) unlatched Outputs will be used to indicate the following calibration status conditions of the Remote sensor.
 - Calibrating ZERO GAS
 - Calibrating SPAN GAS
 - Recovery Time

***NOTE: These outputs are not active during normal operation.**

CALIBRATION ENABLE

The individual Remote sensors can be locked out of the calibration mode to prevent unauthorized or accidental calibration attempts. Authorized personnel can easily and quickly reset this parameter when needed.

- YES** This function must be enabled in order to perform a gas calibration on the selected Remote sensor. The operator can enable the calibration request from the Remote sensor attached to the selected channel by setting the calibration enable parameter to "YES".
- NO** The operator can disable the calibration request from the Remote sensor by setting the calibration enable to "NO". This setting ignores the pushing of the calibration push-button or the magnetic calibration switch activation in the Remote sensor.

SPAN GAS VALUE

The operator must enter the correct value of the Span Gas concentration, which will be used to perform SPAN GAS calibration. The actual gas concentration value should be entered.

ZERO GAS CALIBRATION TIME

This value defines the time period (in seconds) that the system will take to perform a ZERO GAS calibration. This period is the time required for the Remote sensor to provide a stable reading for indication of Zero Gas value upon the activation of the calibration switch. (NOTE:

A setting of 60 = 1 Minute, a setting of 90 = 1 Minute 30 Seconds, a setting of 120 = 2 Minutes and so forth). A minimum of 2 minutes is recommended.

SPAN GAS CALIBRATION TIME

This value defines the time period (in seconds) that the system will take to perform a SPAN GAS calibration. This period should be the time required for the Remote sensor to provide a stable Span Gas reading (from a Zero Gas reading) when the Span Gas is injected into the Remote sensor. (NOTE: A setting of 60 = 1 Minute, a setting of 90 = 1 Minute 30 Seconds, a setting of 300 = 5 Minutes and so forth). A minimum of 2 Minutes is recommended but some sensors may require up to 5 Minutes.

RECOVERY TIME

THE MULTICHANNEL CONTROLLER system performs the gas calibration sequence in the order of Zero Gas and then Span Gas. In order to prevent unnecessary alarms after the Remote sensor calibration, due to the residue of the Span Gas remaining in the Sensor head, a recovery time period (in seconds) can be specified to enable the system to wait until the Remote sensor has returned to its ambient gas monitoring condition. During this recovery time period, the system will maintain an idle state for this channel and will not activate any alarm output for that channel. The other channels are not effected. (NOTE A setting of 60 = 1 Minute, a setting of 90 = 1 Minute 30 Seconds, a setting of 120 = 2 Minutes and so forth). A minimum of 1 to 2 Minutes is recommended.

ALARM TYPE

Three (3) types of Alarm modes can be selected. They are:

- 0-NONE
- 1- LOW - NORMAL - HIGH
- 2- NORMAL - HIGH - HIGH-HIGH
- 3- LOW - LOW - LOW - NORMAL

ALARM LEVEL #1

This value defines the Gas concentration value for the first stage (Warning) Alarm.

ALARM LEVEL #2

This value defines the Gas concentration value for the second state (Alarm) Alarm.

DELAY TO ALARM

This value defines the time delay (in seconds) before the MULTICHANNEL CONTROLLER reports and alarm condition located at the Remote sensor connected to this channel to the LCD display and the alarm output controls. Setting this value to 0 results in no time delay to alarm output activation. A setting of 60 = 1 Minute, a setting of 120 =2 Minutes delay and so forth.

SENSOR LED OPERATION

There is a bi-color LED (Red or Green) installed in each Conspec Remote sensor. This LED can be programmed for indication of the following conditions:

0- OFF all the time.

1 - ON showing normal condition and calibration status of the Remote sensor. As follows:

SLOW FLASHING GREEN-NORMAL CONDITION
CONSTANT RED-SPAN GAS CALIBRATION INITIATED
CONSTANT GREEN-ZERO GAS CALIBRATION INITIATED
RAPID FLASHING GREEN-SENSOR RECOVERY TIME

2- ON ALL CONDITIONS AND ALARMS This is the usual setting for this parameter The LED will show all the statuses and alarms of this Remote sensor as follows:

SLOW FLASHING GREEN - NORMAL CONDITION
FAST FLASHING GREEN - RECOVERY TIME
CONSTANT GREEN - CALIBRATING ZERO GAS

SLOW FLASHING RED - ALARM LEVEL # 1
FAST FLASHING RED - ALARM LEVEL # 2
CONSTANT RED - CALIBRATING SPAN GAS

Raw ZERO Count

This value is the 12-bit Analog to Digital converter reading (0-4095) that represents the Zero Gas value. This number will be automatically updated after calibration. (E.g. for a 4 to 40 mA Remote sensor, 4mA output would represent the Zero Gas value that would approximately equal a value of 800 in the 12-bit Analog to Digital converter reading). -

Raw SPAN Count

This value is the 12-bit Analog to Digital converter reading (0-4095) that represents the FULL Gas value. This number will automatically be calculated and updated after calibration (E.g. For 4 to 20mA Remote sensor, 20mA would represent the maximum gas value that would approximately equal 3800 in the 12-bit Analog to Digital converter reading).

AOUT Zero Count

This is used if the optional Analog Output Module is installed in the MULTICHANNEL CONTROLLER. The operator enters a number (value), which sets the Analog Output value when the sensor is at Zero Gas concentration.

AOUT Span Count

This is used if the optional Analog Output Module is installed in the MULTICHANNEL

CONTROLLER. This allows the operator to define a number (value) that provides an Analog Output from the Analog Output Module which represents the Maximum Gas concentration condition.

CALIBRATION % CHANGE ALARM LEVEL

This is a safety feature that prevent the use of incorrect Gas concentrations for calibration of the Remote sensor. This value sets the maximum deviation of readings from the previous stored values (in percent of change) when the calibration function is activated after the initial set-up. If the readings received from the Remote sensor exceed the previous readings by the specified percentage, the calibration will be considered Invalid and an error message will be displayed on the LCD for several seconds after the recovery time has expired. You must look at the LCD to see if an Invalid calibration has occurred. The previous calibration readings will be retained and used in the event of an Invalid calibration.

ANALOG OUTPUT CHANNEL

For each channel the user can allocate on of the output channels to it by selecting a number 1-8. The processor will send an output to the analog output to that analog output channel representing the gas concentration. A "0" means no analog output channel is allocated to that gas sensor input channel.

AOUT CAL OPERATION

The user can define the analog output channels operating during the calibration stages for that gas sensor. There are five operations for the output operation during calibration.

0-The analog output will follow the actual gas concentration at that sensor.

1-The processor will send out the last analog output valve just before calibration was activated.

2-The processor will send out the low analog output signal that was defined by the user through the calibration

3-The processor will send out the high analog output signal (maximum) throughout the calibration.

4- The process will send out a pulse type analog output signal near the low level throughout the calibration. The user will then be able to identify that the sensor has been calibrated by trending the analog output signal.

AUTO REPORT ON EXCEEDANCE

This function will send the data to the other systems whenever any channel exceeds its preprogrammed alarm levels.

4. SAVE TO EEPROM

This function allows the user to store all programmed data into the EEPROM, data will then be reloaded on start-up or after a power failure. When this function is selected, the LCD will prompt for the password. After entering the correct password (the incorrect password will cause an Exit to the Main Menu), the LCD will prompt:

SAVE CONFIG DATA TO EEPROM OK TO PROCEED (YES/NO)

After confirming by pressing the "ENTER/YES" key, the LCD will prompt:

**SAVE CONFIG DATA TO EEPROM OK TO PROCEED (YES/NO) Y
WRITING BLOCK #0 PLEASE WAIT**

After the data is stored, the system will automatically verify the integrity of the data stored. If the data stored in the EEPROM matches the data in the RAM, the LCD will show:

VERIFYING EEPROM DATA PASSED PRESS ANY KEY TO EXIT

Pressing of any key will cause an Exit to the Main Menu.

****NOTE: After changing any system parameters, changing a channel's configuration or completing a calibration, you must store the data in the EEPROM for the system to use the new data upon system start-up or after a power failure. It is the user's responsibility to store system changes into the EEPROM.**

5. VERIFY EEPROM

This function allows the user to compare the current channel parameters with the data stored in the EEPROM.

6. SET COMM PARAMETER (for CONSPEC TRUNK COMMUNICATION ONLY)

This function is used to enter the parameters required for the communication between the MULIT-CHANNEL CONTROLLER System and the Conspec Central Station over Trunk.

7. ALTER PASSWORD

This function allows the operator to select the password of his own so that unauthorized personnel cannot access the MULIT-CHANNEL CONTROLLER System. This function, when selected, will prompt for the current password. After entering the current password, the LCD will prompt for the new password the operator wants to use. The operator can then enter the password of his choice (up to 4 digits) and press "ENTER/YES" key. The system will prompt the user to re-enter the new password to confirm the password. If the new password was not re-entered correctly, the current password will be retained without alteration. (NOTE: Preset Factory Password is "001")

8. CALIBRATE ANALOG OUTPUT

This function allows the operator to define the analog output ranges for the input gas channel. This function, when selected, will prompt the user for the current password. After a correct password has been entered, the LCD will prompt for the channel number of the Remote sensor that requires calibration of the Analog Output. (This is not the channel number on the analog output card. The channel in the analog output card should already be configured with configure input). After entering the channel number of the gas sensor, the LCD will show:

CALIBRATE ANALOG OUTPUT	
ENTER INPUT CHANNEL#	1
ANALOG OUTPUT CHANNEL #	1
ANALOG OUTPUT ZERO COUNT	40
ANALOG OUTPUT SPAN COUNT	

The LCD will show the following parameters on the LCD

1. The Remote sensor channel number that is currently under analog output calibration.
2. The corresponding analog output channel number which the processor will send the output to (the LED on the analog output card will turn ON to indicate the channel that is currently activated for calibration and remains ON during calibration).
3. The value (between 0 and 255) that will be sent to the output card that in turn provides an analog output representing a Zero Gas concentration.

4. The value (between 0 and 255) that will be sent to the output card that in turn provides an analog output representing a Full Gas concentration.

The user can connect a multi-meter to the channel to read the analog output at Zero count. You can then alter the analog output by clearing, then re-entering the binary value (with the "ENTER/YES" key) until a desired analog output is obtained which represents a Zero Gas count.

When you are finished calibrating the Zero Gas analog output, you can advance to calibrate the analog output for Full Gas concentration by pressing the DOWN Arrow key. Then, clear and reenter the binary value (using "ENTER/YES" key) to obtain a desired analog output for indication of Full Gas conditions.

NOTE: The P2303 Analog Output Module is capable of providing both Voltage and Current output by jumper selection. (Please refer to the jumper settings on Analog Output Module card as shown in Appendix.

Maximum Ranges that can be obtained are:

For Voltage 0 to 5V (0-255)

For Current 0 to 50mA (0-255)

When you are finished calibrating the Analog Output, press the Menu key once. The following menu is now displayed:

CALIBRATE ANALOG OUTPUT

ENTER CHANNEL # (1-8)

The user can now select to calibrate another gas input channel or press the "MENU" key to return to the Main Menu.

9. ENTER CURRENT TIME

This function is used for entering the current time (whenever the controller is powered up the user must re-enter the time) or display of the current time. The time function is used solely for Trend Graphing as mentioned in the "Display Single" function. Once selected, the LCD will display:

ENTER CURRENT TIME

16:47:44

HOUR (0-23): 17

MINUTE (0-59): 26

If a time change is required, first erase the current value by pressing the "CLEAR" key, then reenter the current hour and press "ENTER/YES". Repeat the above for entering the minute. When finished entering the current time, the LCD will prompt:

ACCEPT NEW TIME (Y/N)? _

Press "ENTER/YES" to accept the entry, or "NO" to disregard the changes.

10. ENTER USER PLOT DATA

This function is currently under development for plotting of the Historical Trend Data when a printer is connected via a parallel printer port.

11. **PRINTER REQUEST**

This function prints system information to an attached parallel printer. The options available are:

- 1- INPUT CONFIG - Prints input configurations for a specific channel. (Enter channel #1-8).
- 2- SYSTEM CONFIG - Prints the system configuration data.
- 3 - HEADER - Prints out header information.
- 0- NONE - Terminates the Printer Request Function.

After the selection has been made via the keypad and by pressing the "ENTER/YES" key, the system responds by sending the data to the parallel printer and displaying PRINTER REQUEST ACCEPTED on the LCD. To EXIT, press the MENU key.

12. **DISPLAY MEMORY**

This function is available solely for CONSPEC PERSONNEL use and should not be tampered with. No information would be of interest to the user.

VII. SYSTEM OUTPUTS

(J9 SYS I/O on P2301 MULTIPLE SENSOR INTERFACE Card)

An 8-position pin block is provided on the P2301 Multiple Sensor Interface card for the connection of the system outputs (three (3) open-collector outputs are provided). The system outputs can be used for connection of alarm annunciation devices to signal the status of the P2259/60 MULTI-CHANNEL GAS CONTROLLER System. Note that one of the outputs is nonlatching and that the other two outputs are latching with reset provided by the pressing of any key on the front keypad.

ALL OUTPUTS ARE OPEN COLLECTOR OUTPUTS

Pin # - Description

1 - NON-LATCHING SYSTEM ALARM - ON whenever any one (1) of the attached Remote sensors is in an alarm condition including SENSOR FAIL Alarm. This output will be automatically reset when ALL of the Remote sensors return to the normal condition. If any of the Remote sensors is in an alarm condition, this alarm will remain ON. (Called SYSTEM FAIL Alarm, connected to the STROBE option is provided).

2- GROUND

3- LATCHING SYSTEM ALARM LEVEL #1-ON whenever any one (1) or more of the Remote sensors goes into Alarm Level #1. This output will be LATCHED ON even if all sensors return to a normal condition. To ACKNOWLEDGE this alarm and turn the output OFF, press any key on the keypad. (Called SYSTEM WARNING Alarm).

4- GROUND

5- LATCHING SYSTEM ALARM LEVEL #2-ON whenever any one (1) or more of the Remote sensors goes into Alarm Level #2. This output will be LATCHED ON even if all sensors return to a normal condition. To ACKNOWLEDGE this alarm and turn the output OFF, press any key on the keypad. (Called SYSTEM ALARM, connected to the HORN/SIREN option provided.)

6- GROUND

7- NOT USED

8- NOT USED

Two (2) SPDT relays are provided in the P2259/60 MULTI-CHANNEL GAS CONTROLLER System unless otherwise ordered. One relay is connected to the open collector output alarm Level # 1 and labeled "SYSTEM WARNING". The other relay is connected to the open collector output alarm Level #2 and labeled "SYSTEM ALARM". These outputs will be LATCHED ON even if all sensors return to a normal condition To ACKNOWLEDGE these alarms and turn the relays OFF, press any key on the keypad.

****NOTE:** After acknowledging these alarms, if the same Remote sensor(s) remains in Alarm Level #1 or Alarm Level #2, the corresponding alarm output WILL NOT RE-LATCH ON. If the same Remote sensor(s) returns to NORMAL then (or a different Remote sensor(s) reaches Alarm Level # 1 or Alarm Level #2 states, then the corresponding alarm output will latch ON.)

VIII. USER OUTPUTS

Four (4) open collector outputs are provided for each channel of the P2259/60 MULTI-CHANNEL GAS CONTROLLER System. Sixteen (16) outputs in the P2259 and thirty- two (32) outputs in the P2260. These outputs provide the user with sensor Status of NORMAL, ALARM LEVEL #1, ALARM LEVEL #2, and SENSOR FAIL. These same outputs can be programmed to show the CALIBRATION STATE of the Remote sensor: CAL ZERO GAS, CAL SPAN GAS, and SENSOR RECOVERY if the user desires. Please refer to APPENDIX A and drawing #10828 of this manual for output connection information and the USER OUTPUT OPERATION for programming the output responses. One or two 20-position phoenix style connectors are provided for easy connection of the user outputs. These outputs can be used to drive relays or other devices (strobes and horns).

IX. AVAILABLE OPTIONS

OPTIONAL 4-20mA or 0-5V OUTPUT

The P2303 analog output cards should not be connected until after the initial system calibration. The outputs should be wired according to drawing #10829 and the jumpers set according to Appendix B. The outputs should be connected to the users devices and calibrated after all other calibration procedures have been completed. ****MOST PROBLEMS ENCOUNTERED ARE CAUSED BY INCORRECT WIRING.**

OPTIONAL PARALLEL PRINTER PORT

Connect the ribbon cable supplied with the P2342 Parallel printer Port card to plug J8 on the P2301 Multiple Sensor Interface board. Connect a standard printer cable between the DB-25 parallel port connector and the parallel printer. Do not power up the printer until after the initial system configuration has been completed.

OPTIONAL RS-232 SERIAL PORTA RS232 serial communication can be installed for connecting the P2259/60 MULTI-CHANNEL GAS CONTROLLER SYSTEM to another device in the serial mode. Please contact the factory for further information.

X. REMOTE SWITCH CALIBRATION (For Distance Of The Remote sensor)

Once the Remote sensor is installed and properly connected, and before a gas calibration can be performed on the Remote sensor, the calibration switch sensitivity has to be calibrated on the P2273 Remote Cell Interface Card. The calibration switch sensitivity allows the user to vary the voltage on the cable pair carrying the information on calibration switch activation.

1. Set Dip Switch #1 on the P2275 CPU Board to the ON position for a cold startup then press and release the CPU RESET Switch. (See Appendix for locations).
2. Slide the miniature slide switch towards the LED. (on older version P2273, move the 2 position Jumper on W1 of the P2273 Remote Cell Interface Card to jumper the two (2) pins closer to the LED).
3. Turn Trimpot P1 on the P2273 Remote Cell Interface Card "COUNTER-CLOCKWISE" until the Red LED (CAL. SW) located on the card turns ON.
4. Now Turn Trimpot PI "CLOCKWISE" One Complete Turn, the Red LED (CAL. SW) should turn OFF.
5. Have someone Press and Hold down the Calibration Switch in the Remote sensor at the location of the Remote sensor you are adjusting. You must do this for each sensor. (NOTE: Some Remote sensors use a magnetic proximity detector Switch The magnet should be held over the proximity detector and remain there to activate the switch and keep it activated for this and the next step).
6. Notice that the Red LED (CAL. SW) on the P2273 Remote Cell Interface Card will turn ON when the calibration switch is activated.
7. Instruct the person to Release the Calibration Switch on the Remote sensor and you will notice that the Red LED (CAL. SW) should turn OFF. If this is not the case, repeat the above from Step 1. (NOTE: With a Remote sensor(s) that uses a magnetic proximity switch, remove the magnet that was being held over the proximity detector to deactivate the switch).

NOTE: This calibration is extremely important. If the sensitivity of the Remote Switch is not calibrated correctly, the improper calibration will cause the controller to repeatedly go into the calibration mode for that particular sensor. You must calibrate each Remote Switch on every Remote sensor connected to the controller.

8. Slide the miniature slide switch away from the LED. (On older version of P2273, Move the Jumper W1 on the P2273 Remote Cell Interface Card back to its original position so that the two (2) pins toward the center of the card are jumpered together).
9. Set Dip Switch #1 on the P2275 CPU Board to the OFF position and press the CPU Reset Button. This enables the CPU Board to reload the EEPROM data upon recycling of the power (or in case of AC power failure).
10. Configure the software for channel (i.e. Remote sensor) connected to the P2259/60 Multichannel Controller (NOTE: The system's parameters for all channels are pre-configured by the factory. See CONFIG INPUTS under MAIN MENU if changes need to be made).

The Remote Switch calibration is now completed. Re-calibrate the remote switch sensor will not be required unless sensor is moved, or cable is adjusted or replaced. The user is required to perform a GAS CALIBRATION on each Remote sensor upon Start-up and then at least monthly (or whenever required by those in charge of Safety at the installed location) to ensure that the system is operational.

XI. GAS CALIBRATION OF A REMOTE SENSOR (Auto Calibration)

Prior to starting the gas calibration allow at least ½ hour after power-up for sensor to stabilize. Insure the “Calibration Enable” parameter is marked “YES”. Have the proper calibration equipment available. To begin calibration, follow these instructions:

1. Activate the Remote sensor Calibration procedure by Pressing and Holding, for at least (1) Second, the Calibration Switch on the Remote sensor. (NOTE: For a Remote sensor that uses a magnetic proximity detector switch, hold the magnet over the proximity detector for at least 2 seconds to activate.
2. After activating the Calibration Switch, the LED on the Remote sensor should turn CONSTANTLY GREEN. This indicates a ZERO GAS calibration is in progress. (NOTE: if the LED DOES NOT TURN GREEN it indicates that there is a problem in activating the calibration process. The Remote Switch calibration was not performed properly or the channel that the sensor is attached has the “Calibration Enable” feature de-activated).
3. Insert the proper calibration adaptor plug into the cell housing of the Remote sensor and inject the proper ZERO GAS at the correct flow rate for the sensor. (Most sensors require a flow rate of 0.5 LPM (liter per minute). Maintain a constant flow of ZERO GAS while the LED in the Remote sensor is CONSTANTLY GREEN in color.
4. After a predefined ZERO CALIBRATION TIME has elapsed, the LED on the Remote sensor will turn CONSTANTLY RED. This indicates a SPAN GAS calibration is now in progress.
5. Remove the ZERO GAS and inject the SPAN GAS of the correct concentration and at the correct flow rate for the Remote sensor. Maintain a constant flow of SPAN GAS while the LED in the Remote sensor is CONSTANTLY RED in color.
6. After the predefined SPAN CALIBRATION TIME has elapsed, the LED on the Remote sensor will become a FAST FLASHING GREEN color. This indicates a Recovery Period is in progress for the Remote sensor.
7. Remove the SPAN GAS from the Remote sensor. The gas calibration for the Remote sensor has now been completed.
8. When all of the Remote sensors have been calibrated, make sure to perform a “SAVE TO EEPROM” (Use the Keypad & Menu on the Controller to do this), to save all of the calibration data.

INVALID CALIBRATION

If the calibration is INVALID, an error message “CAL FAIL” will be displayed on the LCD when the channel is viewed. (NOTE: Most invalid calibrations are caused by not injecting the gas or by injecting the wrong gas during calibration). When an INVALID CALIBRATION occurs, the new calibration readings are discarded and the old calibration readings will be restored for this channel.

XII. MANUAL GAS CALIBRATION OF REMOTE SENSORS

1. Go to **VIEW SINGLE CHANNEL**. Apply ZERO Gas to the sensor for 1 to 2 minutes until the reading stabilizes. Note the reading (ex. Reading is 800). This is your RAW Zero Count.
2. Apply SPAN Gas to the sensor for 2 to 3 minutes until the reading stabilizes. Note down the reading. (Ex. Reading is 2,300).
3. Now deduct the Raw Zero Count from this reading. (Ex. $2,300 - 800 = 1500$). This is the change for $\frac{1}{2}$ Scale Gas or 50% - so for Full Scale Gas, the reading becomes $1500 \times 2 = 3000$.
4. Now add the 3000 with the offset (800), for a total of 3800 and this becomes your new Raw SPAN Count.
5. Go back to "Configure Inputs" on the MAIN MENU for the channel you were just working with and make your changes using the keypad. Erase the old figures under Raw ZERO Count & enter the new figure (Ex. 800 & Enter). Erase the old figures under Raw SPAN Count & enter the new figure (Ex. 3,800 & Enter).
6. Now go to the MAIN MENU and Save to the EEPROM.

Conspec Technical Services: 724-489-8450

XIII. APPENDICES

Appendix A

USER OUTPUT CONNECTIONS (ON P2301 MULTI-SENSOR I/O CARD)

	CHANNEL #	STATUS	CAL.STATUS
J4-1	1	NORMAL	CAL. ZERO
2	1	ALARM LEVEL # 1	CAL. SPAN
3	1	ALARM LEVEL # 2	RECOVERY
4	1	SENSOR FAIL	
5	N/C		
6	GROUND		
7	2	NORMAL	CAL ZERO
8	2	ALARM LEVEL # 1	CAL. SPAN
9	2	ALARM LEVEL # 2	RECOVERY
10	2	SENSOR FAIL	
11	3	NORMAL	CAL. ZERO
12	3	ALARM LEVEL # 1	CAL. SPAN
13	3	ALARM LEVEL # 2	RECOVERY
14	3	SENSOR FAIL	
15	GROUND		
16	GROUND		
17	4	NORMAL	CAL. ZERO
18	4	ALARM LEVEL # 1	CAL. SPAN
19	4	ALARM LEVEL # 2	RECOVERY
20	4	SENSOR FAIL	
J5-1	5	NORMAL	CAL. ZERO
2	5	ALARM LEVEL # 1	CAL. SPAN
3	5	ALARM LEVEL # 2	RECOVERY
4	5	SENSOR FAIL	
5	N/C		
6	GROUND		
7	6	NORMAL	CAL ZERO
8	6	ALARM LEVEL # 1	CAL. SPAN
9	6	ALARM LEVEL # 2	RECOVERY
10	6	SENSOR FAIL	
11	7	NORMAL	CAL. ZERO
12	7	ALARM LEVEL # 1	CAL. SPAN
13	7	ALARM LEVEL # 2	RECOVERY
14	7	SENSOR FAIL	
15	GROUND		
16	GROUND		
17	8	NORMAL	CAL. ZERO
18	8	ALARM LEVEL # 1	CAL. SPAN
19	8	ALARM LEVEL # 2	RECOVERY
20	8	SENSOR FAIL	

APPENDIX B

On our P2301 Multi-Sensor I/O card, J8 is provided for connection to J6 on the P2303 Multi-Analog Output card that provides analog output channels. If 4 extra analog output channels are required, a second P2303 can be added by connecting the J6 of the second P2303 to the J5 of the first P2303 analog output card. However, a different jumper setting is required to identify the address of the analog output card.

Jumper Settings of P2303 Analog Output Card

W1	OUT-For 24V Operation IN-for 15V Operation (Not recommended due to current consumption)
W2-B W-47-B	For the first Analog Output Card (I.e.) Channel #1 to Channel #4 Analog Output
W2-A W47-A	For the second Analog Output Card (I.e.) Channel #5 to Channel #8 Analog Output even though card is labeled Ch.1 to Ch.4

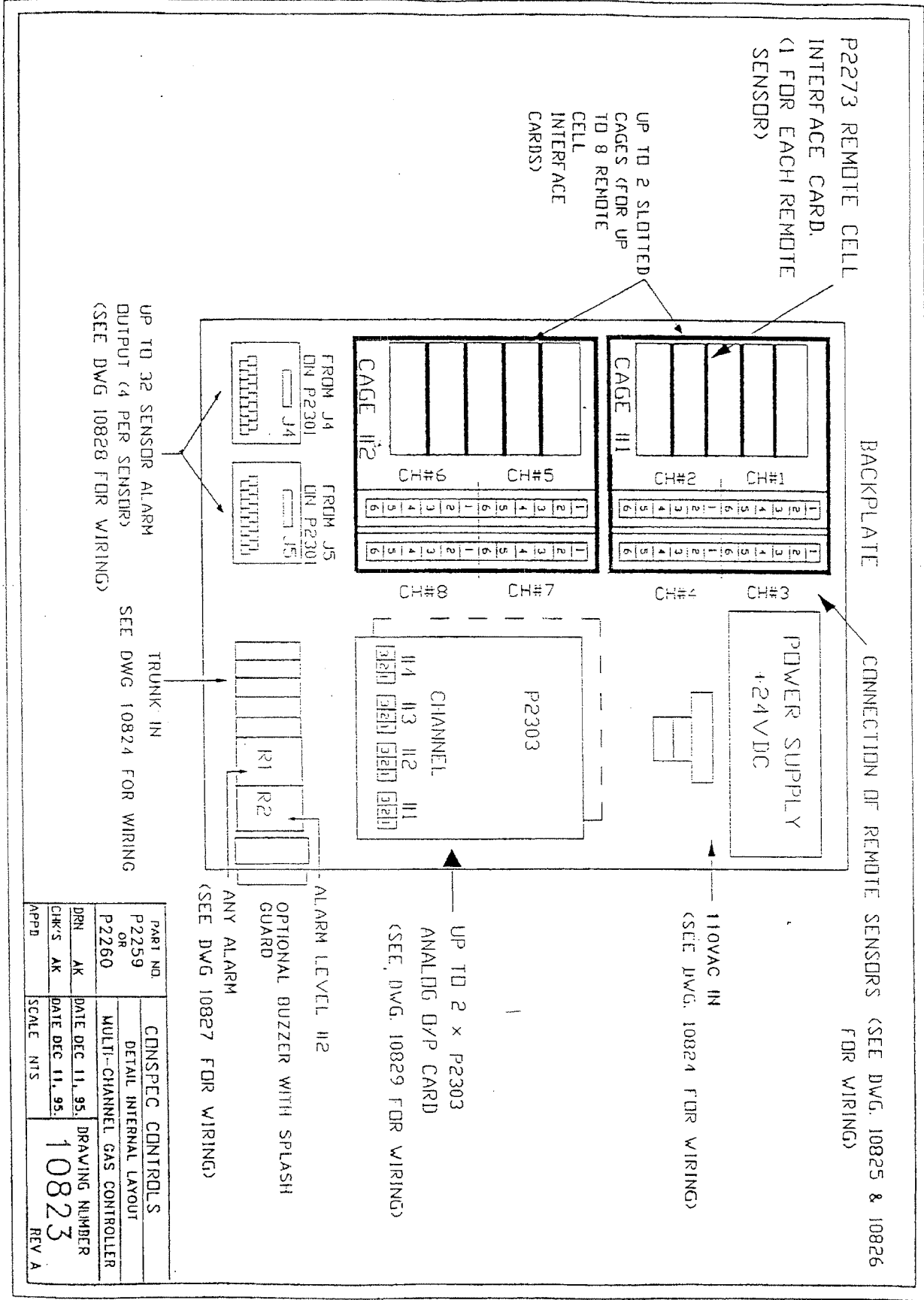

PART NO. P2259 OR P2260	CONSPEC CONTROLS DETAIL INTERNAL LAYOUT MULTI-CHANNEL GAS CONTROLLER
DRN AK	DATE DEC 11, 95.
CHK'S AK	DATE DEC 11, 95.
APPD	SCALE NTS
	DRAWING NUMBER 10823
	REV A

FIELD WIRING DIAGRAM OF REMOTE SENSOR

FOR 4 WIRE REMOTE SENSOR : (O₂, CO, NO, NO₂, SO₂, CL₂, NH₃, HCL)

P2259/60
MULTI-CHANNEL
GAS CONTROLLER

CH#1-8

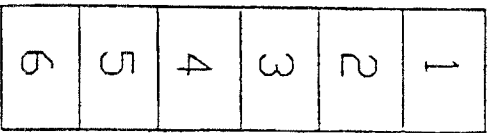

TERMINAL BLOCK
ON CAGE

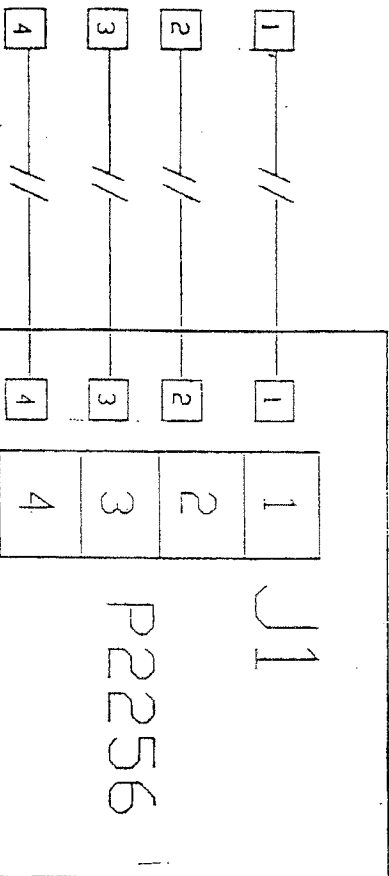

PART NO. P2259 OR P2260	CONSPEC CONTROLS FIELD WIRING DIAGRAM
DRN AK	REMOTE 4 WIRE SENSOR TO MULTI-CHANNEL GAS CONTROLLER
CHK'S AK	DATE DEC 11, 95.
APPD	SCALE NTS
	DRAWING NUMBER 10825
	REV A

FIELD WIRING DIAGRAM OF REMOTE COMBUSTIBLE SENSOR (5 WIRE)

P22559/60
MULTI-CHANNEL
GAS CONTROLLER

CH#1-8

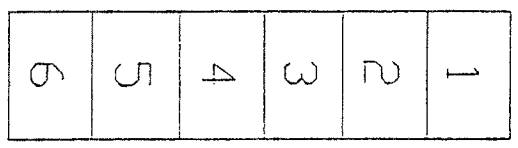

TERMINAL BLOCK
ON CAGE

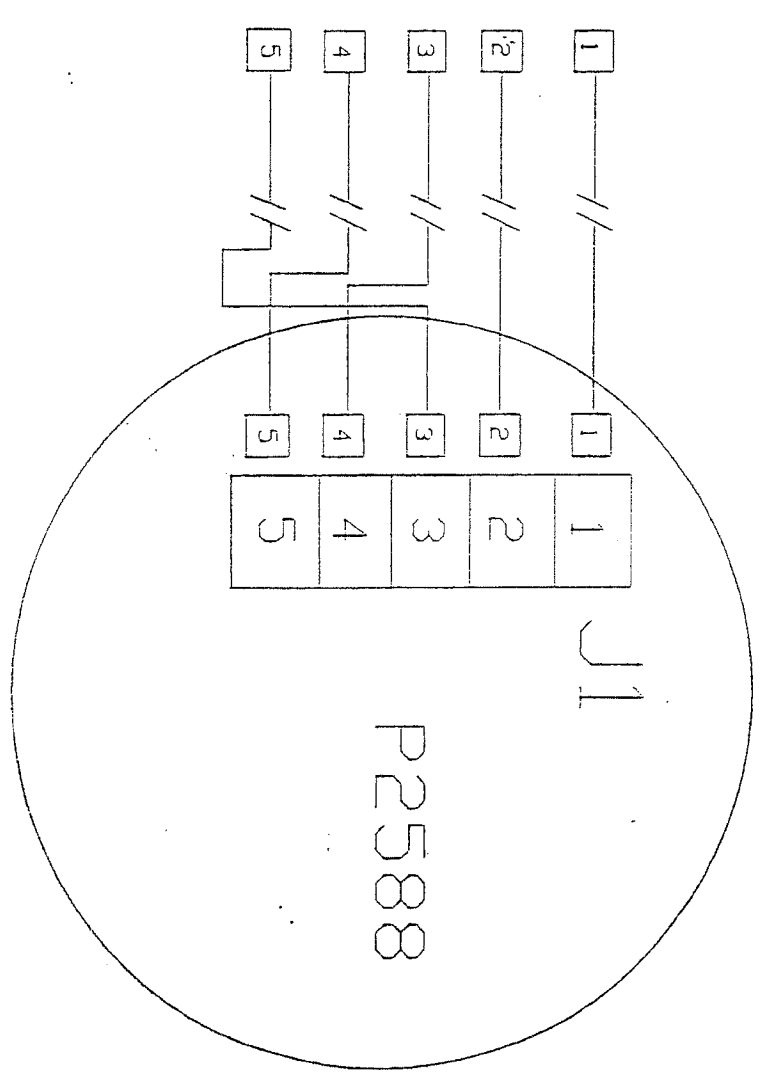

PART NO. P2259 OR P2260	CONSPEC CONTROLS	
DRN AK	FIELD WIRING DIAGRAM	
CHK'S AK	REMOTE COMBUSTIBLE SENSOR TO MULTI-CHANNEL GAS CONTROLLER	
APPD	DATE DEC 11, 95.	DRAWING NUMBER 10826
	DATE DEC 11, 95.	REV A
	SCALE NTS	

WIRING DIAGRAM OF SYSTEM ALARMS (3 AVAILABLE, OPTIONAL WITH RELAYS)

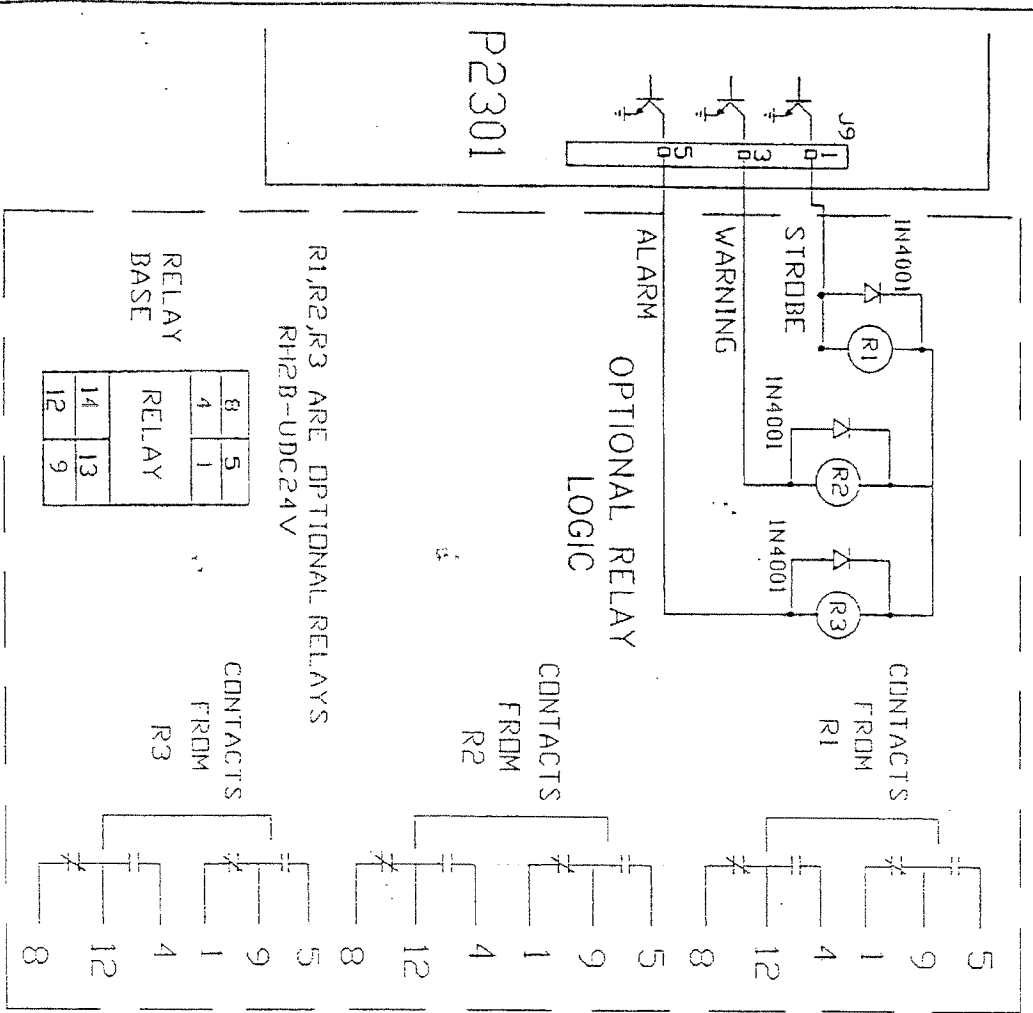

RECOMMEND WIRING

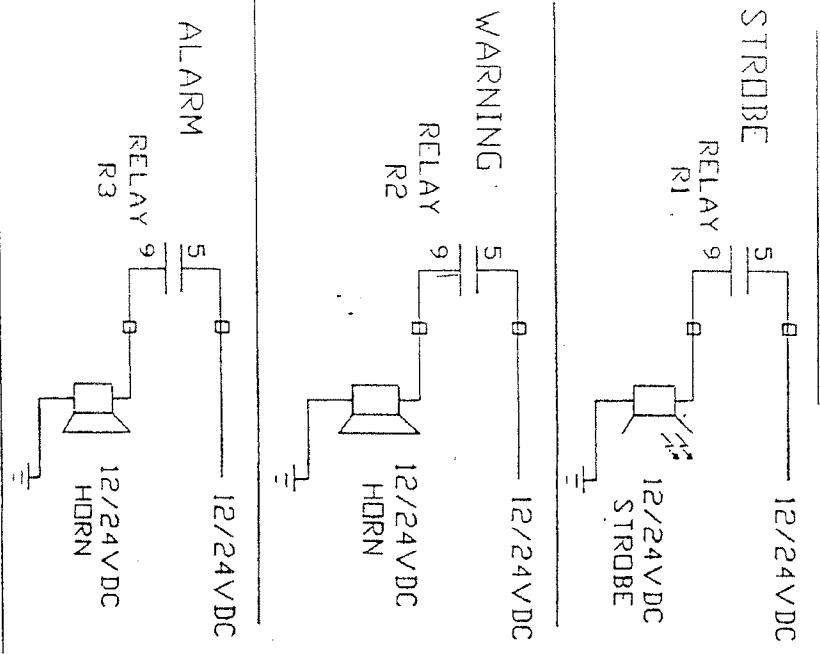

PART NO P2259 OR P2260 DRN AK CHK'S AK	CONSPEC CONTROLS FIELD WIRING DIAGRAM SYSTEM ALARMS (RELAYS) TO MULTI-CHANNEL GAS CONTROLLER DATE DEC 11, 95 DRAWING NUMBER 10827 REV A
APPD	SCALE NTS

INDIVIDUAL ALARM OUTPUT

(4 OPEN COLLECTOR OUTPUT PER CHANNEL)

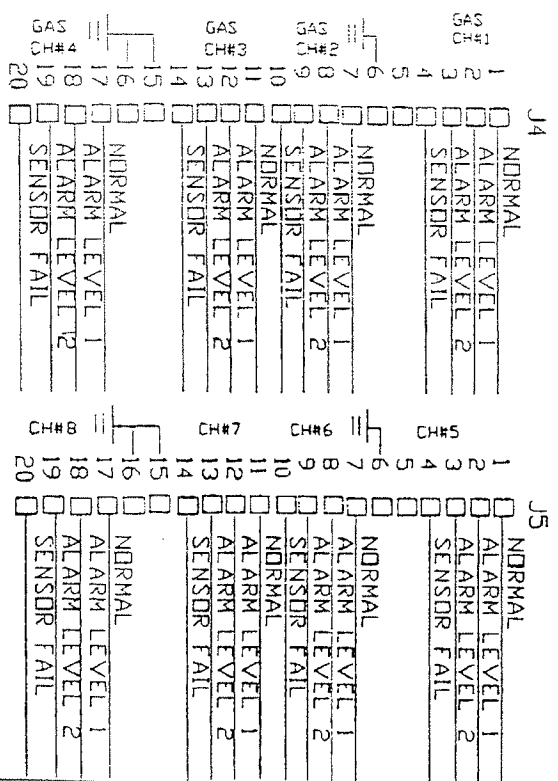
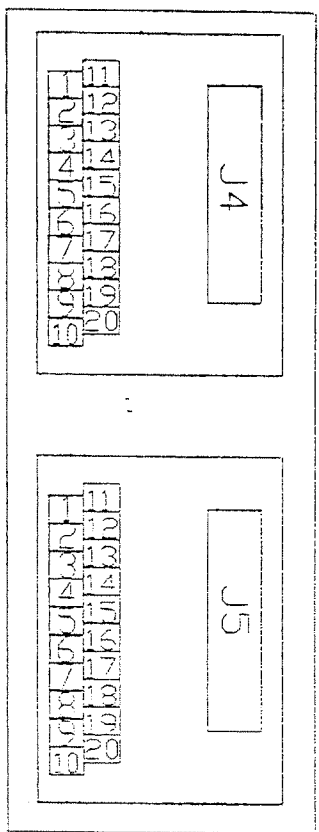

Recommend Wiring (E.G. for CH11)

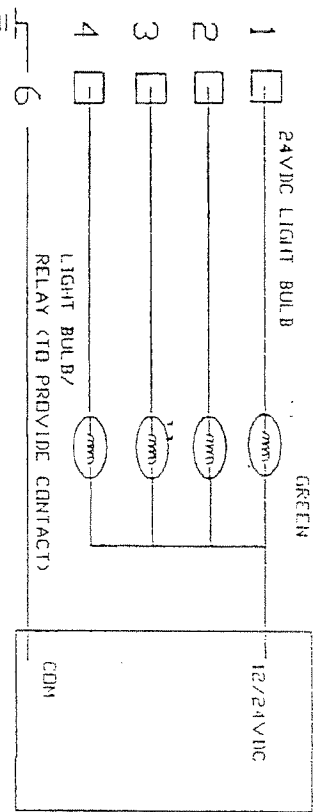

NB
EACH OUTPUT (NORMAL, ALARM LEVEL 1, ALARM LEVEL 2, SENSOR FAIL) IS OPEN COLLECTOR OUTPUT CAPABLE OF SINKING 100mA MAX.

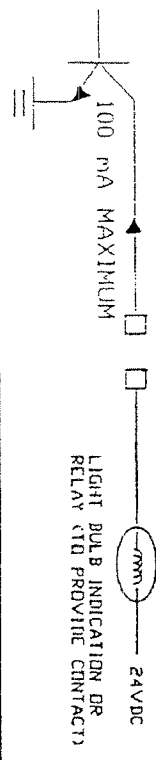

PART NO. P2259 OR P2260	CONSPEC CONTROLS	
DRN AK	FIELD WIRING DIAGRAM	INDIVIDUAL ALARM OUTPUTS
CHK'S AK	DATE DEC 11, 95.	MULTI-CHANNEL GAS CONTROLLER
APPD	SCALE NTS	DRAWING NUMBER
		10828
		REV A

FIELD WIRING DIAGRAM

FOR ANALOG OUTPUT

OPTION

OPTIONAL 1ST ANALOG OUTPUT BOARD

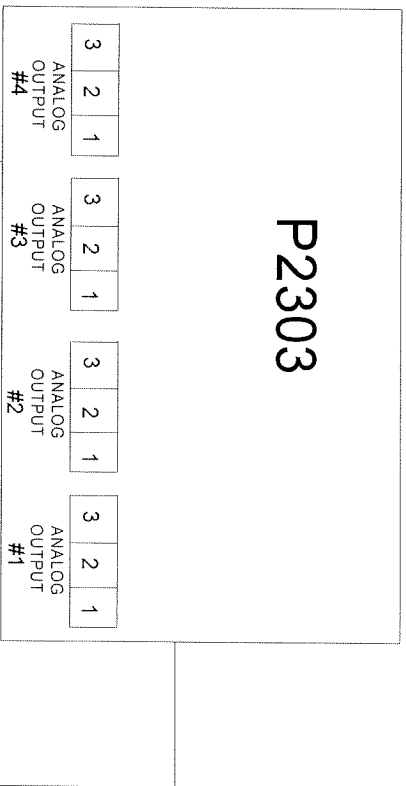

FIELD WIRING

ANALOG OUTPUT #1 - 4

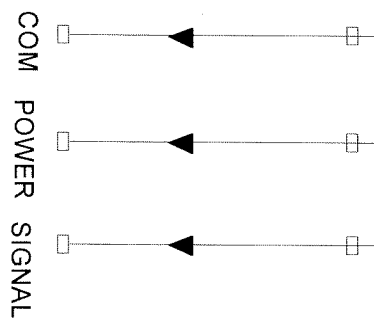
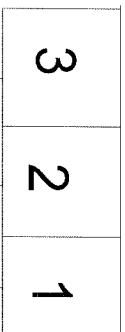

OPTIONAL 2ND ANALOG OUTPUT BOARD

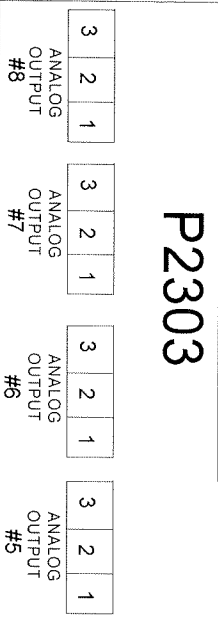

ON 1ST ANALOG OUTPUT BOARD

OUTPUT #1 = OUTPUT CHANNEL #1

- #2 = " "
- #3 = " "
- #4 = " "

ON 2ND ANALOG OUTPUT BOARD

OUTPUT #1 = CHANNEL #5

- #2 = " "
- #3 = " "
- #4 = " "

PART NO. P2259 OR P2260	CONSPEC CONTROLS	
	FIELD WIRING DIAGRAM	
DRN	AK	DATE FEB 10, 05.
CHKS	AK	DATE FEB 10, 05.
APPD		SCALE NTS
DRAWING NUMBER 10829		REV C

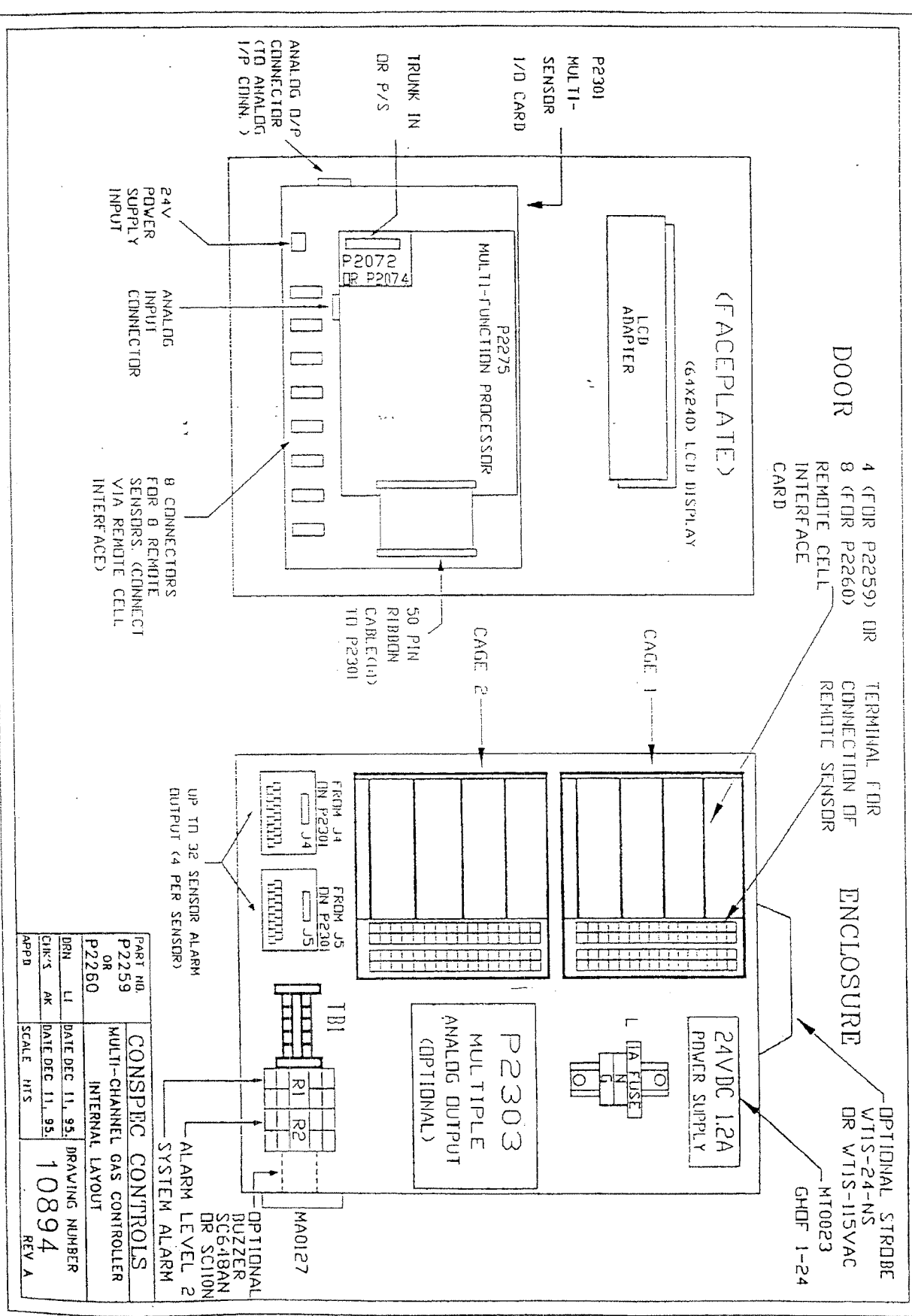

PART NO.	P2259	CONSPEC CONTROLS
OR	P2260	MULTI-CHANNEL GAS CONTROLLER
DRN	LI	INTERNAL LAYOUT
CHK'S	AK	DATE DEC 11, 95
APPD		SCALE HTS
		DATE DEC 11, 95
		DRAWING NUMBER
		10894
		REV A

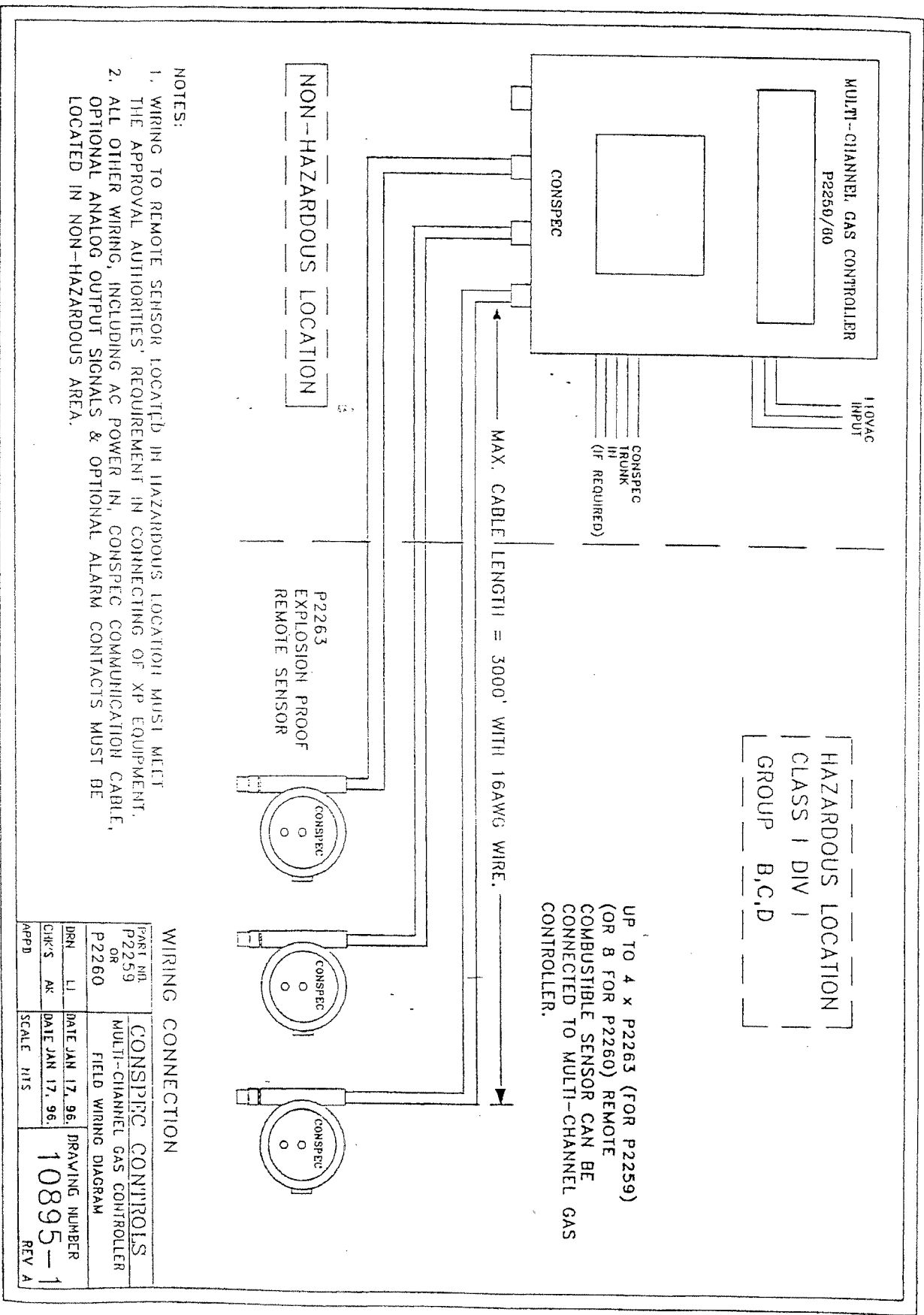

- NOTES:
1. WIRING TO REMOTE SENSOR LOCATED IN HAZARDOUS LOCATION MUST MEET THE APPROVAL AUTHORITIES' REQUIREMENT IN CONNECTING OF XP EQUIPMENT.
 2. ALL OTHER WIRING, INCLUDING AC POWER IN, CONSPREC COMMUNICATION CABLE, OPTIONAL ANALOG OUTPUT SIGNALS & OPTIONAL ALARM CONTACTS MUST BE LOCATED IN NON-HAZARDOUS AREA.